



Booleroo Centre District School

... Strive to Excel

Integrity · Responsibility · Resilience · Respect

Newsletter Term 3 Week 1

Dates for the Diary
1st AUGUST, 2024

****School Photos****

Monday 5th August

[Senior Badminton](#)

Tuesday 6th August

[7/8 Boys MNSEC Footy](#)

Tuesday 6th August

[ADF Presentation 10s–12s](#)

Tuesday 6th August

[4/5/6 5-a-side soccer carnival](#)

Wednesday 7th August

[Year 10/11 Subject](#)

[Counselling](#)

Thursday 8th–Friday 9th

August

[7/8 MNSEC 5-a-side soccer](#)

Thursday 8th August

[Year 9 Ski Trip](#)

12th–16th August

[Year 11 Work Experience](#)

12th–16th August

[SAPOL anti bullying and](#)

[violence workshop](#)

Monday 12th August

[Sapsasa AFL girls trials 4pm](#)

Tuesday 13th August

[Patch Theatre excursion](#)

[Kindy–Year 3](#)

Tuesday 20th August

[Year 9-10 Fast 5 Netball](#)

Thursday 29th August

Student Free Day

Friday 13th September

School Closure

Monday 16th September

Principal's News

Welcome Back

Welcome back to term three. Term three will be quite busy with PAT testing to be held and various other extra curricula activities such as camps, excursions, SAPSAS events and information sessions for our students as they begin to look at their respective pathways.

Developing Sensory corner resource

We are excited to announce the introduction of Sensory Corner in our library! This initiative is designed to enhance our students' learning experiences by providing a dedicated space to help them regulate their emotions and improve focus.

What is a Sensory Corner?

A Sensory Corner is a specially designed area where students can go to calm themselves, refocus, and manage overwhelming emotions before they escalate or maybe after they have escalated, depending on the student's needs. The corner is equipped with various tools and activities tailored to meet different sensory needs, helping students achieve a greater sense of balance and readiness to engage in their learning.

Our Goal

The primary goal of the Sensory Corner is to support students in managing their emotions and choices, enabling them to succeed academically and socially. By offering this resource, we aim to help students become more self-regulated and focused, creating a more positive and productive classroom environment.

What We Are Working On

As we roll out the Sensory Corner, we are focusing on several key areas:

Identifying Students in Need: Ensuring that the Sensory Corner is accessible to students who will benefit most from this support.

Establishing Rules and Expectations: Develop clear guidelines for using the Sensory Corner to ensure it is used effectively and respectfully.

Tracking and Collecting Data: Determining what information to monitor to assess the impact and effectiveness of the Sensory Corner.

Staffing and Scheduling: Organizing how and when the Sensory Corner will be available, and how we can sustainably staff it.

Space Utilization: Evaluating and optimizing the space used for the Sensory Corner, with flexibility for future adjustments.

Ongoing Development

We understand that implementing the Sensory Corner is a work in progress. We are committed to continuously refining and improving this initiative to best meet the needs of our students. Your feedback and observations will be invaluable as we move forward.

We believe that Sensory Corner will be a valuable addition to our educational environment, and we are confident that it will contribute positively to our students' well-being and success. This initiative will also support classroom teachers who do not currently have Sensory Corners in their classrooms.



Government
of South Australia
Department for Education

PO Box 42 Booleroo Centre SA 5482
PH: 08 8667 2124 · F: 08 86672201

E: dl.0771_info@schools.sa.edu.au · W: www.booleroods.sa.edu.au

Kindy&Rural Care

PH: 08 8667 2055 · F: 08 8667 2039

E: dl.6608.leaders@schools.sa.edu.au · W: www.boolerookan.sa.edu.au

Principal's News (cont)

Bus Safety and Road Rules

As the new term begins, it's important to remember the following reminders for both students using buses and drivers on the road. During school drop-off and pick-up times, the roads become especially busy with children walking, biking, and using school buses. Given that young children are particularly vulnerable, it's crucial for everyone to stay vigilant and exercise caution near schools or drop-off points when school buses are running.

Here are some tips on the road rules that apply if you are heading to work or school or driving near schools.

25km/h around schools

25km/h speed limits apply within school zones, at children's crossings when the lights are flashing and when passing a school bus that has stopped to pick up or drop off children. School zones are signed, and zigzag lines are marked on the road where practicable to indicate that you are approaching a school zone.

P1 Passenger restrictions

If you're driving to school, remember that passenger restrictions apply to P1 Licence holders under the age of 25. Immediate family members are exempt so you can take a brother or sister but you can only carry one friend aged 16 to 20. This law applies at any time of day or night unless a qualified supervising driver is seated next to you or you meet the exemption criteria. We also have a school policy about students driving to and from school, with formal forms required to be filled in if your child is seeking to drive to school or take siblings with them.

If you are not sure about any of the road rules or wish to discuss this with your child, please refer to;

www.myllicence.sa.gov.au/safe-driving-tips

Growth Mind Set

"True progress is achieved when we embrace our challenges with courage and perseverance. Every obstacle is an opportunity to grow stronger and reach new heights. Let us move forward with unwavering faith in our potential and a commitment to support each other's journey."

Martin Luther King Jr

Progress and success come from facing difficulties with bravery and determination. It suggests that challenges should be seen as chances to improve and become better. By having faith in our own abilities and supporting one another, we can achieve great things and continue to grow. The message encourages a positive outlook and mutual encouragement in the pursuit of personal and collective goals. Learning is facing difficulties and being determined and not being afraid to fail and try again.

Thank you,

Tas Ktenidis

Kindy News

A warm welcome to our two children starting Kindergarten this term and their families. In our first week, we are connecting as a new Kindy group and having lots of fun in the process.

Currently, we are participating in our own Kindy Olympics. Each week, our little athletes are exploring different Olympic sports. The children are choosing the events/sports they would like to participate in and we have medal presentations after the events. We are celebrating the joy of movement, perseverance, and teamwork – values that are at the heart of the Olympics. This has also encouraged learning about which country is hosting the Olympics, France's flag, our Australian Flags and the Olympic rings.

Children are sharing a family photo for 'Show and Share' as we continue to learn about each other.



Kindy News (cont)



Quote: "Children learn through doing – play is how they explore their world, learn how to assess risk, try things out and get to know themselves." Bethe Almeras

The Kindy Team

Senior School News

Much information comes into the school around careers, VET, universities, TAFE, scholarships etc. All relevant information is passed onto students through Microsoft Teams either through their Home Group or EIF (the new PLP) class. Please encourage your children to check out the information regularly so they can keep up with the many options and experiences available to them. Anyone with any questions can contact me at school anytime.

Subject Counselling – Initial subject selection forms were due back last Friday. The next step for students and parents is to attend subject counselling interviews next week. As per the note that went home last week, **appointments for these meetings can now be made using the online Interviewsd booking system on Sentral**. There are no classes for Year 10 and 11 students on **FRIDAY 9th of OCTOBER** in lieu of interviews. There are also some spots still available on Thursday afternoon. We strongly encourage all parents to come along to a session with their child. Please make your appointment by next Tuesday

RAP – Year 11s attended the Road Awareness Program in Orroroo last week. This continues to be an incredibly valuable and worthwhile experience for our young drivers. If you haven't seen it, I encourage you to speak to your child about the driving agreement included in the resources given to the students at the end of the session.

Year 11 Work Experience - 12th - 16th of August. The paperwork has been sent home and can also be found on Sentral and in HG Teams. Arrangements need to be finalised by the end of this week.



Gayle Bury
Senior School Coordinator
gayle.burydodman794@schools.sa.edu.au

Year 11 Design & Technology

Integrity · Responsibility · Resilience · Respect

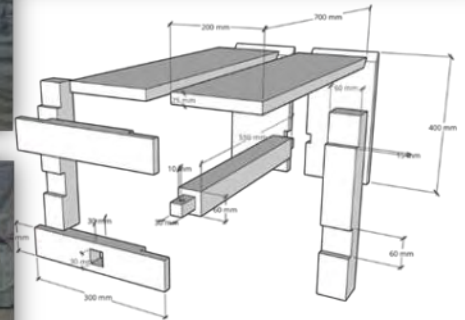
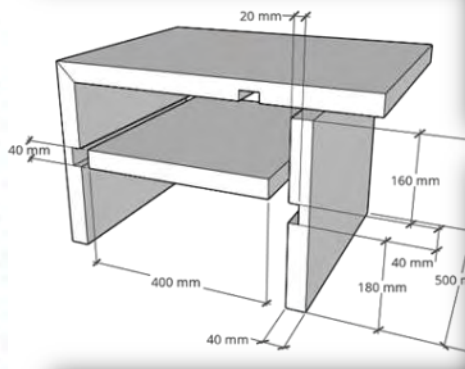

Year 11 Design & Technology students have consolidated their learning using Computer Aided Design (CAD), developing project drawings for production in the workshop. The task was to design and then construct a waterfall end coffee table, using a minimum of three timber joints in the construction.

In the process, students learning included the safe operation of workshop tools and equipment, and the various capabilities of many of the tools being used. All tables are put together using timber joints and glue only, no nails or screws used in the final product.

Each table is unique in its design, using a variety of new and recycled timbers. Students should be extremely proud of their finished products.

Steve Couch

Design & Technology Teacher